

Analog Phone

ALN-5203/ALN-5200

AKD-5203/AKD-5200

QIG v1.0



1 Over view

This phone is a full-feature telephone that provides voice communication. Read this QIG carefully to learn how to operate this product and take advantage of its features.

Package Contents

When unpacking the Analog phone, ensure all the following items are present and undamaged. If anything appears to be missing or broken, contact your dealer for a replacement.

1. Base Unit
2. Handset
3. Coiled Handset Cord
4. Line Cord
5. Clear Plastic Faceplate
6. User Guide

2 Product Description

This chapter contains important information to help you familiarize yourself with the functions of the Analog phone.

Front View



	Name	Description
1	Ring Indicator	A red light indicator means that you have incoming calls or signals that a message is waiting for retrieval.
2	Dialing Pad	Press the buttons to dial a phone number or enter alphabetical characters.
3	Speed dial keys	Press to dial one touch of guest services or PBX features. Programmed during installation.
4	Flash	Press to provide momentary line break typically used for accessing PBX features such as transfer calls.
5	Redial	Press to automatically redial the last number dialed
6	Hold	Press to hold the line without disconnect the line.

	Name	Description
7	LINE 1/LINE 2	There are two LINEs in this Analog Phone.

3. Installation

The following illustration shows how to install the phone and stand.

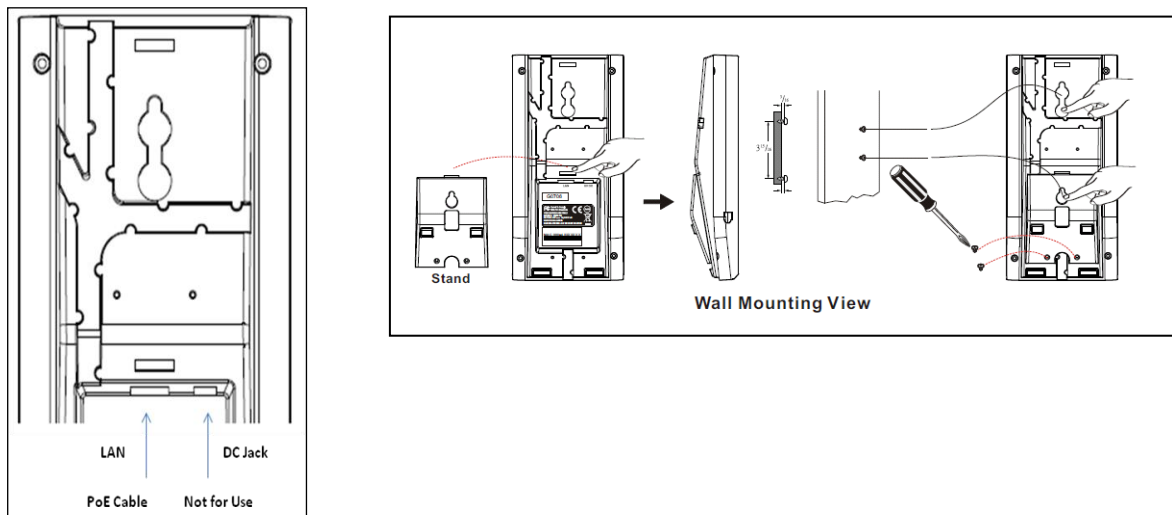

4 Operation

Selecting Line 1 and Line 2

Line 1 or Line 2 can be activated by pressing one of the latching line keys labeled LINE 1 or LINE 2. Use the HOLD key to place callers on hold while connecting to the other line.

Answering a Call

An incoming call is indicated by a ringing tone and a flashing indicator at the top of handset. You can answer the call by doing one of the followings:

- Pick up the **handset** to answer the call.

Making a Call

Dialing with the Keypad

- Enter the telephone number with the alphanumerical keypad.

Using The Hold Key

To place a call on hold

- With a call active, press the HOLD key.
- The line LED will change from green to red indicating the call is on hold.
- Replace the handset without hanging up the call while on hold.

To resume the call from hold

- Press the line key of the call on hold.
- The line LED will change from red to green.

Changing line after placing a call on hold

- Place the call on hold, as above.
- Select the inactive line by pressing the line key.
- Lift the handset and make a call or receiving a call.

For technical support, please email to support@aeicommunications.com.tw
