

VoIP DECT Phone

SGR-8206-SMK / SGR-8106-SMK

SGR-8206-SMKE / SGR-8106-SMKE

QIG v1.0



1 Overview

This phone is a full-feature telephone that provides voice communication. Read this QIG carefully to learn how to operate this product and take advantage of its features.

Package Contents

When unpacking the phone, ensure all the following items are present and undamaged. If anything appears to be missing or broken, contact your dealer for a replacement.

1. Base Unit
2. Cordless Handset
3. Stand
4. Battery
5. AC Adaptor
6. RJ-45 Cable
7. Quick Installation Guide (This document)

2 Product Description

The following contains important information to help you familiarize with the functions of the VoIP phone.

Front View



1. Handset keys

	Name	Description
1	Message waiting indicator	To indicate an incoming call or unread messages.
2	Display screen	To display calls and status information.
3	Speed dial keys	Press to dial the preset number.
4	LINE 1 / LINE 2	To indicate a line been used as the following status: - Idle: No LED indication. - In call: Red LED. - In on-hold call: Blinking red LED.

	Name	Description
5	End key	Press to end a phone call
6	Alphanumerical keys	Press these keys to enter phone numbers or texts.
7	Function keys	
	Hold	Press to put an active call on hold.
	Speaker	Press to activate the speakerphone for hands free conversations.
	Volume	Press to increase or decrease the volume of the ringer tone, handset, or speakerphone.

2 Base unit keys

	Name	Description
1	Message waiting indicator	To indicate an incoming call or unread messages.
2	Speed dial keys	Press to dial the preset number.
3	LINE 1 / LINE 2	To indicate a line been used as the following status: - Idle: No LED indication. - In call: Red LED. - In on-hold call: Blinking red LED.
4	End key	Press to end a phone call
5	Alphanumerical keys	Press these keys to enter phone numbers or texts.
6	Function keys	
	Hold	Press to put an active call on hold.
	Speaker	Press to activate the speakerphone for hands free conversations.
	Volume	Press to increase or decrease the volume of the ringer tone or speakerphone.

Back View

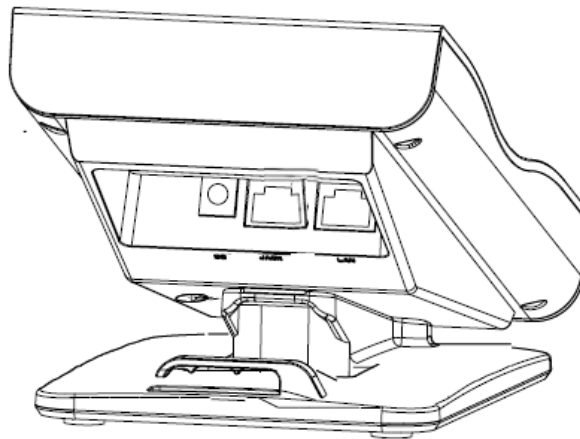

NO.	Name	Description
1	LAN port	Connects to HUB, ADSL, or Switch(PSE)
2	PC port	Connects to computer
3	DC jack	Connects to AC power adapter. (Optional. While base unit is not powered via a PSE)

Connecting the Phone

The following illustration shows how to connect the power, LAN and PC ports of VoIP phone.

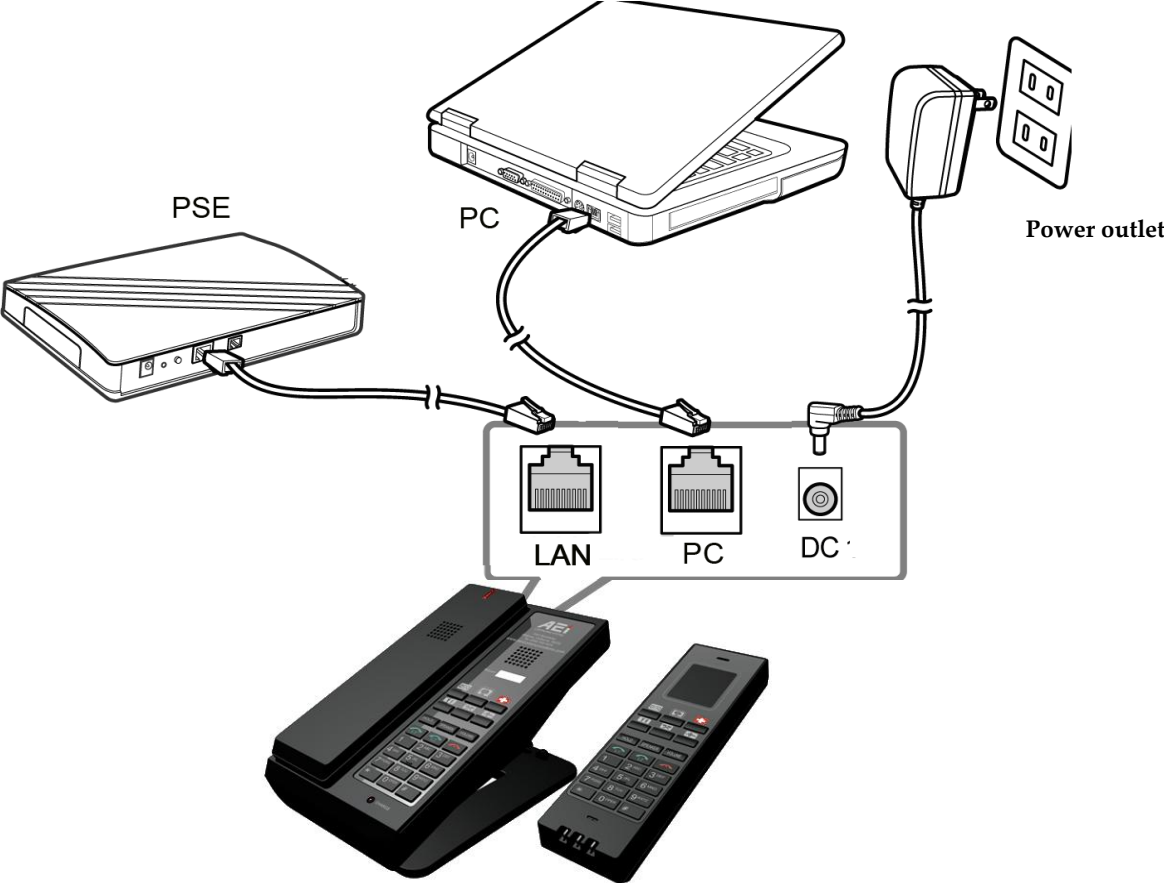

The following illustration shows how to install the phone and stand.

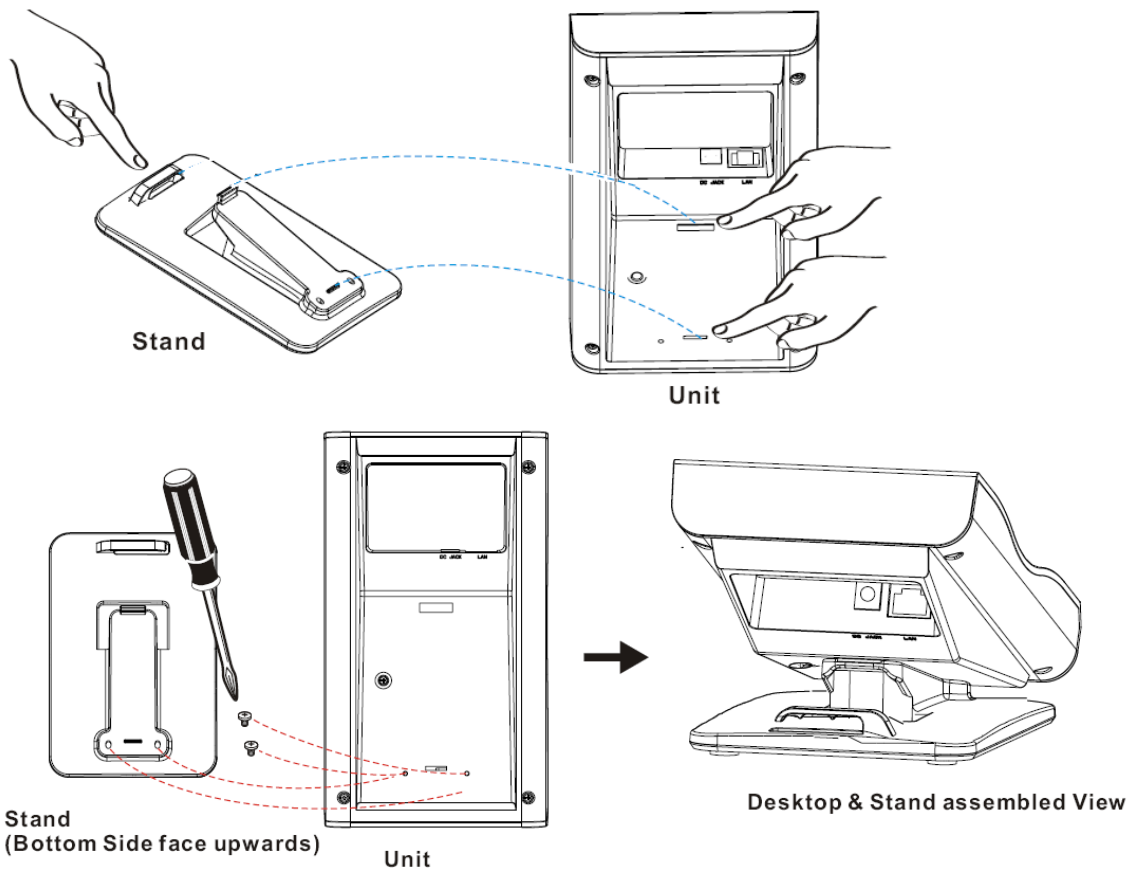

The following illustration shows how to install the handset and battery.

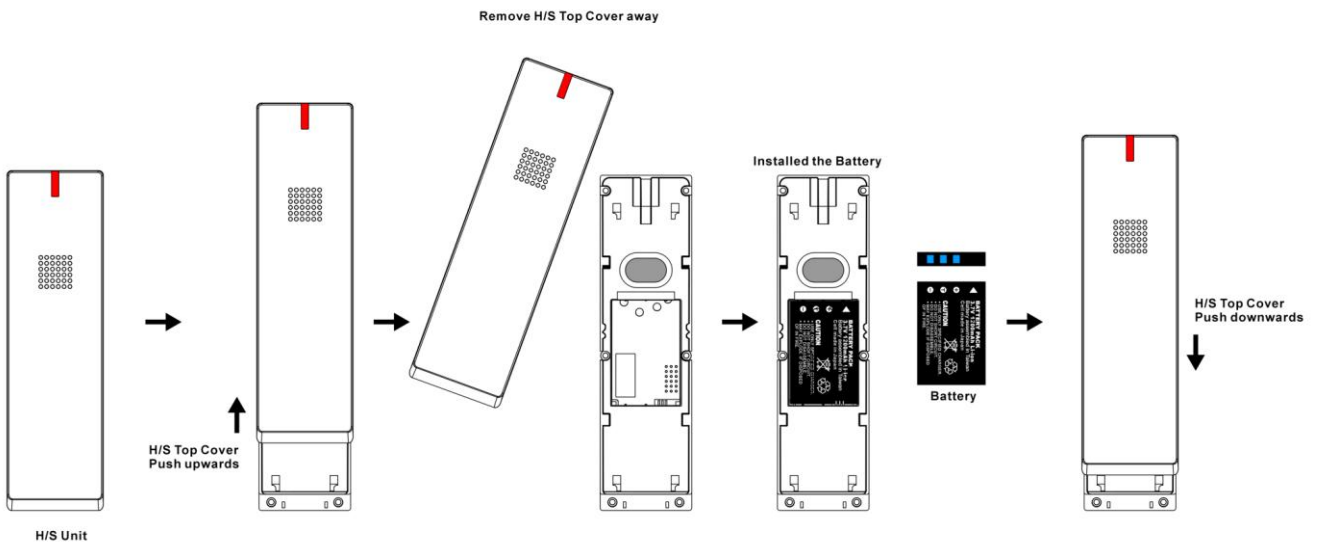

3 Operations

Answering a Call

An incoming call is indicated by a ringing tone and a flashing indicator at the top of both handset and base units. You can answer the call by doing one of the followings:

- Pick up the **handset** to answer the call.
- Press the **Line (Line1/Line2)** key on the base or handset to answer the call.

Making a Call

Dialing with the Keypad

- Enter the telephone number with the alphanumeric keypad and the call will start automatically.

Using the Speed dial keys

You can use the 6 pre-assigned speed dial hotkeys, to configure the most commonly dialed numbers. Use the function to dial a number quickly, instead of keying in a complete number.

To call a number using speed dialing, follow the steps below:

- Press the speed dial hotkey that has been pre-assigned to the phone number and the call will start automatically.

Call Options

While a call is in progress, a number of additional options are available.

Using the Speaker Phone

For hands free operation, you can use the built-in speaker to talk on the phone. To use the speakerphone, follow the steps below:

- While talking on the phone, press the **SPEAKER** key on the phone to enable the Speakerphone function.
- Press Speaker key again to terminate the call.

Putting a Call on Hold

You may want to put a call on hold temporarily while doing some work or attending to a second incoming or outgoing call. To put a call on hold, do one of the following:

- Press the **HOLD** key on the phone to put the call on hold.
- When you receive a second call, press the next available **LINE** key to attend to the new call, and the first call will be put on hold automatically.

Charging the Handset Battery

You would need to charge the handset battery before using the handset.

- Install the battery into the handset.
- Place the handset onto the base unit and base unit will start to charge the handset automatically.
- The charging indicator lights up in red during charging progress. The LED goes off after the handset battery is fully charged.

Checking Voice Messages

If the **message waiting indicator** at top of handset or base unit lights up in red, it indicates that there are one or more new messages in voicemail box.

- Press the **MESSAGE** key on the phone to retrieve voice messages.

(An external ITSP or PBX must support voice message feature. And you need to set a voice message code before using the voice mail feature.)

4 Support

To configure through the web browser, do the following:

- Ensure the phone is powered up and connected to a DCHP network.
- Press HOLD/MUTE *112*113# (HOLD for 2-Line / MUTE for 1-Line), the IP address is announced by the phone.
- Open your browser (such as Chrome, Firefox, etc.) and type in the web address of the phone. For example, http://IP.address.of.thePhone:8000

When the Web login front page is displayed. Enter the user name and the password and click **Login**.
The administrator's user name and password are "**admin**" and "**1234**" respectively.

For technical support, please email to support@aeicomunications.com.tw

Model:

SGR-8206-SMK / SGR-8106-SMK
SGR-8206-SMKE / SGR-8106-SMKE
