

SIP DECT Phone



SGR-8106-SMKE Non-Display

QIG
V 1.00

1 Overview

This phone is a full-feature telephone that provides voice communication. Read this QIG carefully to learn how to operate this product and take advantage of its features.

Package Contents

When unpacking the phone, ensure all the following items are present and undamaged. If anything appears to be missing or broken, contact your dealer for a replacement.

1. Base Unit
2. Cordless Handset
3. Stand
4. Battery
5. AC Adaptor
6. RJ-45 Cable
7. Quick Installation Guide (This document)

2 Product Description

The following contains important information to help you familiarize with the functions of the VoIP phone.

Front View



1. Handset keys

	Name	Description
1	Message waiting indicator	To indicate an incoming call or unheard voice messages.

	Name	Description
2	Speed dial keys	Press to dial the preset number.
3	LINE key	Press to make a phone call
4	End key	Press to end a phone call
5	Function keys	
	MUTE	Press to mute handset MIC.
	SPEAKER	Press to activate the speakerphone for hands free conversations.
	VOLUME	Press to increase or decrease the volume of the ringer tone, handset, or speakerphone.
6	Alphanumerical keys	Press these keys to enter phone numbers.

2 Base unit keys

	Name	Description
1	Message waiting indicator	To indicate an incoming call or unheard voice messages.
2	Speed dial keys	Press to dial the preset number.
3	LINE key	To indicate a line been used as the following status: - Idle: No LED indication. - In call: Red LED.
4	End key	Press to end a phone call
5	Function keys	
	MUTE	Press to mute base unit MIC.
	SPEAKER	Press to activate the speakerphone for hands free conversations.
	VOLUME	Press to increase or decrease the volume of the ringer tone or speakerphone.
6	Alphanumerical keys	Press these keys to enter phone numbers.

Rear View

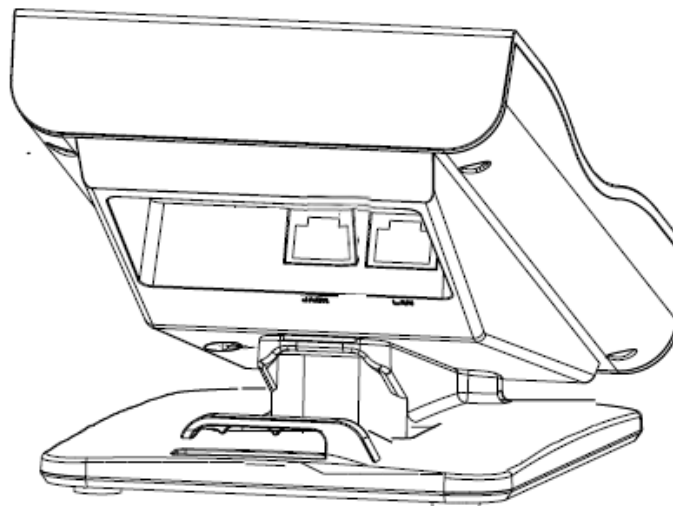

NO.	Name	Description
1	LAN port	Connects to HUB, ADSL, or Switch(PSE)
2	PC port	Connects to computer

Connecting the Phone

The following illustration shows how to connect the power, LAN and PC ports of VoIP phone.

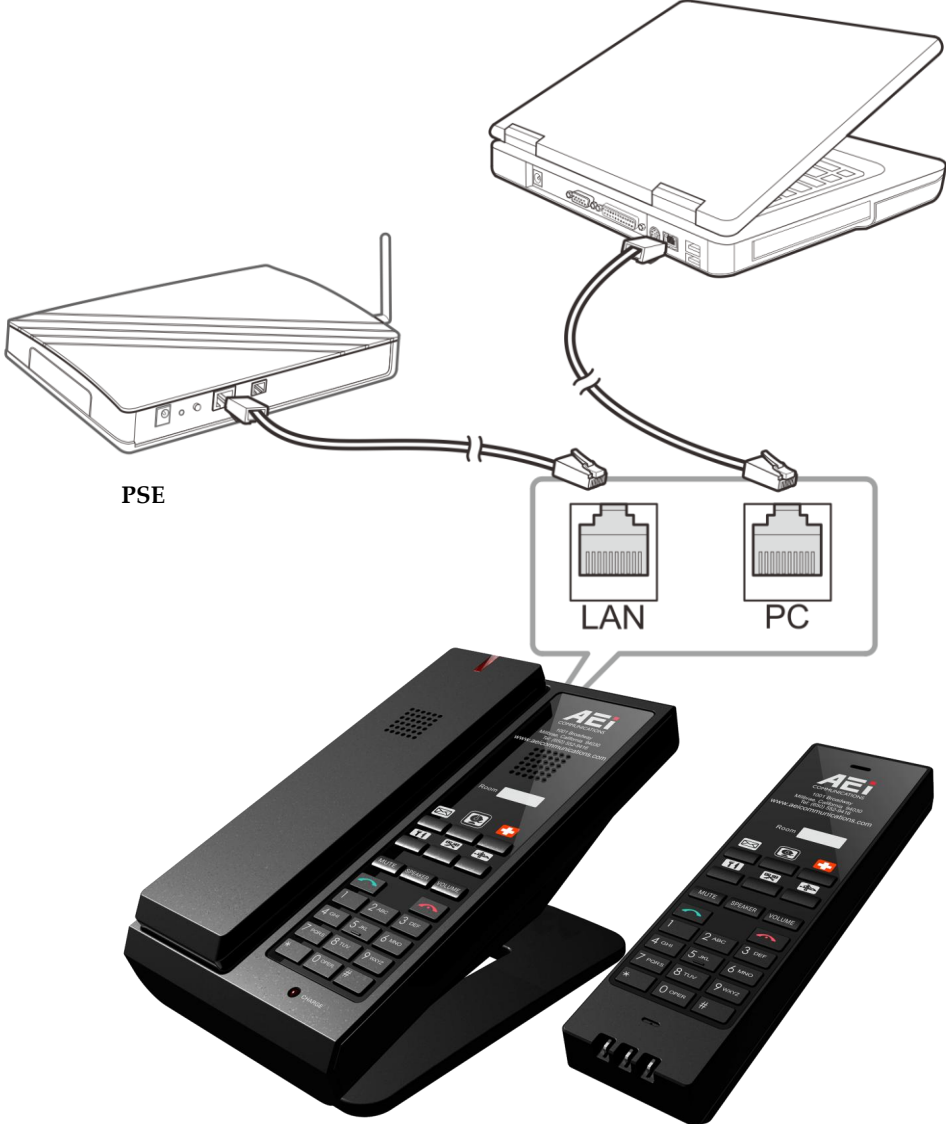

The following illustration shows how to install the phone and stand.

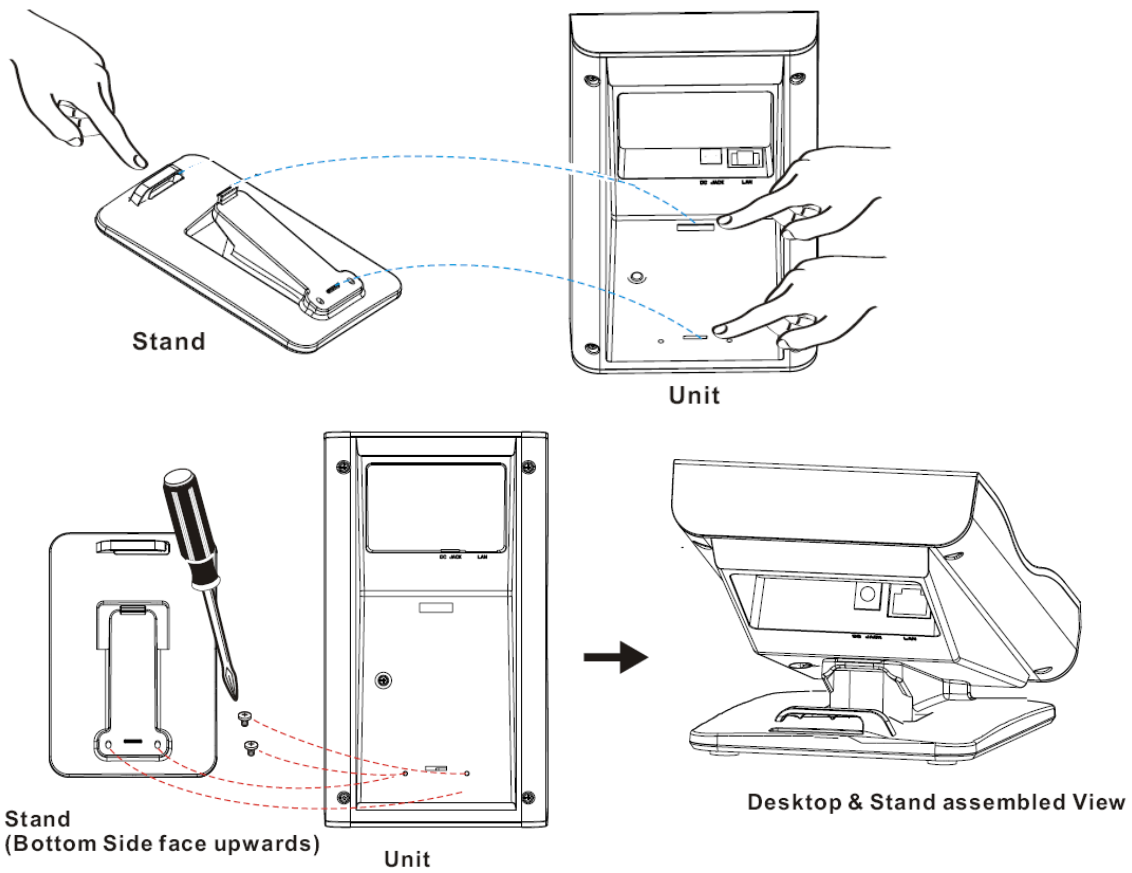

The following illustration shows how to install the handset and battery.

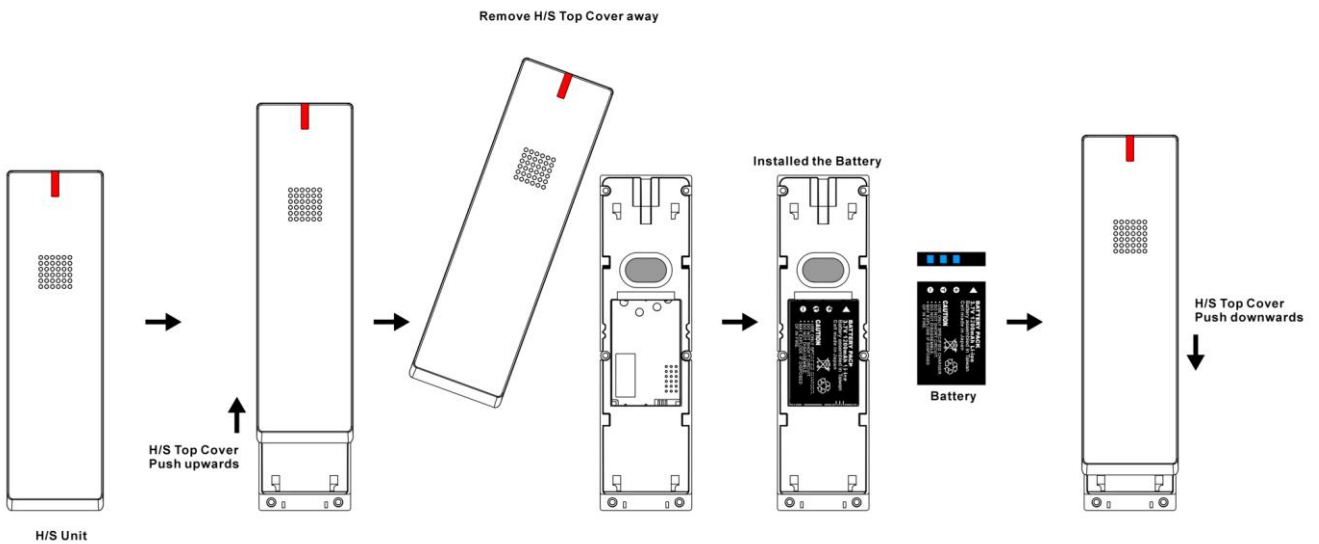

3 Operations

Answering a Call

An incoming call is indicated by a ringing tone and a flashing indicator at the top of both handset and base units. You can answer the call by doing one of the followings:

- Pick up the **handset** to answer the call.
- Press the **Line** key on the base or handset to answer the call.

Making a Call

Dialing with the Keypad

- Enter the telephone number with the alphanumeric keypad and the call will start automatically.

Using the Speed dial keys

You can use the 6 pre-assigned speed dial hotkeys, to configure the most commonly dialed numbers. Use the function to dial a number quickly, instead of keying in a complete number.

To call a number using speed dialing, follow the steps below:

- Press the speed dial hotkey that has been pre-assigned to the phone number and the call will start automatically.

Call Options

While a call is in progress, a number of additional options are available.

Using the Speaker Phone

For hands free operation, you can use the built-in speaker to talk on the phone. To use the speakerphone, follow the steps below:

- While talking on the phone, press the **SPEAKER** key on the phone to enable the Speakerphone function.

Mute a Call

You may need to mute MIC temporarily during a call, do one of the following:

- Press the **MUTE** key on the phone to mute the microphone.
- Press the **MUTE** key again to unmute microphone.

Charging the Handset Battery

You would need to charge the handset battery before using the handset.

- Install the battery into the handset.
- Place the handset onto the base unit and base unit will start to charge the handset automatically.
- The charging indicator lights up in red during charging progress. The LED goes off after the handset battery is fully charged.

Checking Voice Messages

If the **message waiting indicator** at top of handset or base unit lights up in red, it indicates that there are one or more new messages in voicemail box.

- Press the **MESSAGE** key on the phone to retrieve voice messages.

(An external ITSP or PBX must support voice message feature. And you need to set a voice message code before using the voice mail feature.)

4 Support

To configure through the web browser, do the following:

- Ensure the phone is powered up and connected to a DHCP network
- Press HOLD/MUTE *112*113# (HOLD for 2-Line / MUTE for 1-Line) on the base, the IP address is announced by the phone. Or Press *112*113 and then "LINE 1" (for 2-line phone) or green button (for 1- line phone) on the cordless handset, the IP address is displayed on the LCD screen.
- Open your browser (such as Internet Explorer, Firefox, etc.) and type in the web address of the phone. For example, if the IP address you obtain in step 4 above is 192.168.1.2, enter the web address: http:// 192.168.1.2:8000.
- When the Web login front page is displayed. Enter the user name and the password and click **Login**. The administrator's user name and password are "**admin**" and "**1234**" respectively.

For technological support, please email to support@aeicommunication.com.
