

# SIP DECT Phone



VM-8208-SMK(S) / VM-8108-SMK(S)  
VM-8208-SMKG(S) / VM-8108-SMKG(S)  
VM-8208-SMKU(PoE) / VM-8108-SMKU(PoE)

**QIG**

**V 1.02**

For single Ethernet models

---

# 1 Overview

This phone is a full-feature telephone that provides voice communication. Read this QIG carefully to learn how to operate this product and take advantage of its features.

## Package Contents

When unpacking the phone, ensure all the following items are present and undamaged. If anything appears to be missing or broken, contact your dealer for a replacement.

1. Base Unit
2. Cordless Handset
3. Stand
4. Battery
5. AC Adaptor (Optional)
6. RJ-45 Cable
7. Quick Installation Guide (This document)

## 2 Product Description

The following contains important information to help you familiarize with the functions of the VoIP phone.

### Front View

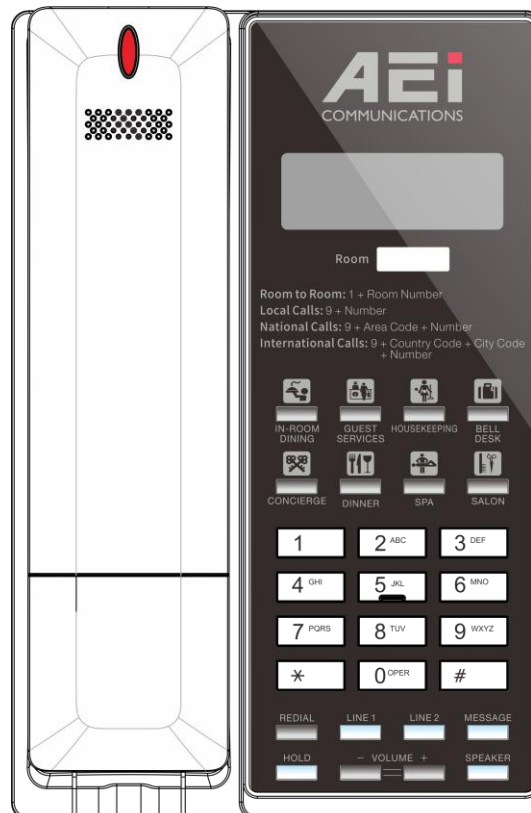

1. Base unit keys

	Name	Description
1	Display screen	To display calls and status information.
3	SELECT SERVICES key	Press enter service function
5	Alphanumerical keys	Press these keys to enter phone numbers and texts.
6	Function keys	
	LINE 1 / LINE 2	To indicate a line been used as the following status: - Idle: No LED indication. - Pre-dialing a call: Green LED. - In call: Red LED.
	HOLD (2 line only)	Press to put an active call on hold.
	MUTE (single line only)	Press to mute MIC.
	Redial	Press to call the last number dialed.
	Speaker	Press to activate the speakerphone for hands free conversations.
	Volume up/down	Press to increase or decrease the volume of the ringer tone or speakerphone.
	Message	Press to retrieve voice messages.



## 2 Handset keys

item	Name	Description
1	Display screen	Displays calls and status information.
2	SELECT SERVICES key	Press enter service function
3	Right / Left key	Press to choose service function.
4	LINE 1 / LINE 2	There are two LINES bottom in this handset.
5	END key	Press to end the phone call
6	Alphanumerical keys	Press these keys to enter phone numbers and texts.
	Function keys	
	HOLD (2 line only)	Press to put an active call on hold.
	MUTE (single line only)	Press to mute MIC.

item	Name	Description
	SPEAKER	Activates the speakerphone to allow hands free conversations.
	VOLUME	Press to increase or decrease the volume of the ringer tone, handset, or the volume of the current call using the speakerphone. There are three levels: small, middle and large volume.
	MESSAGE	Press to listen to voice messages.
	GUEST SERVICES	Press to contact guest services.
	<b>EMERGENCY</b>	Press to make an emergency call.

## Back View

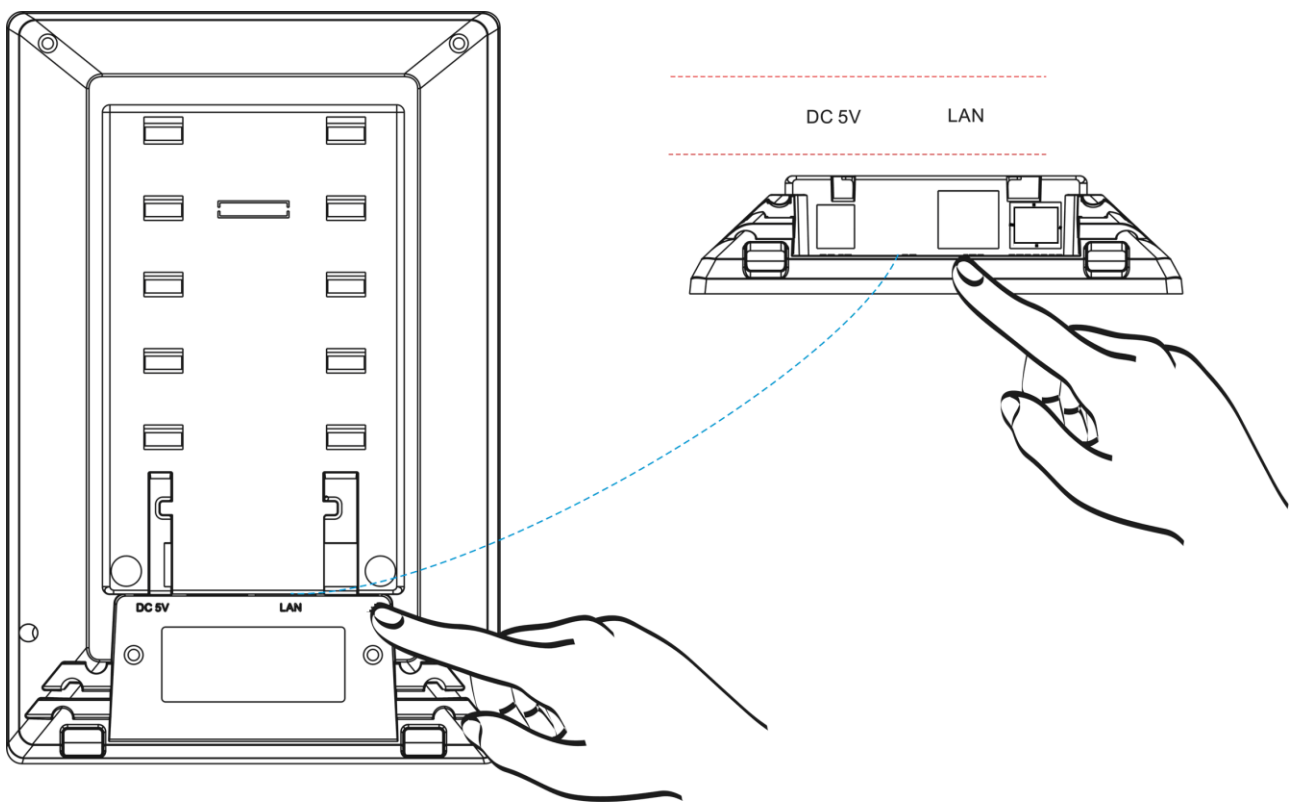

NO.	Name	Description
1	LAN port	Connects to HUB, ADSL, or Switch(PSE)
2	DC 5V Power jack	Connects to AC power adapter. (Optional. While base unit is not powered via a PSE)
3	Handset jack	Connects to handset.

## Connecting the Phone

The following illustration shows how to connect the power and LAN ports of VoIP phone.

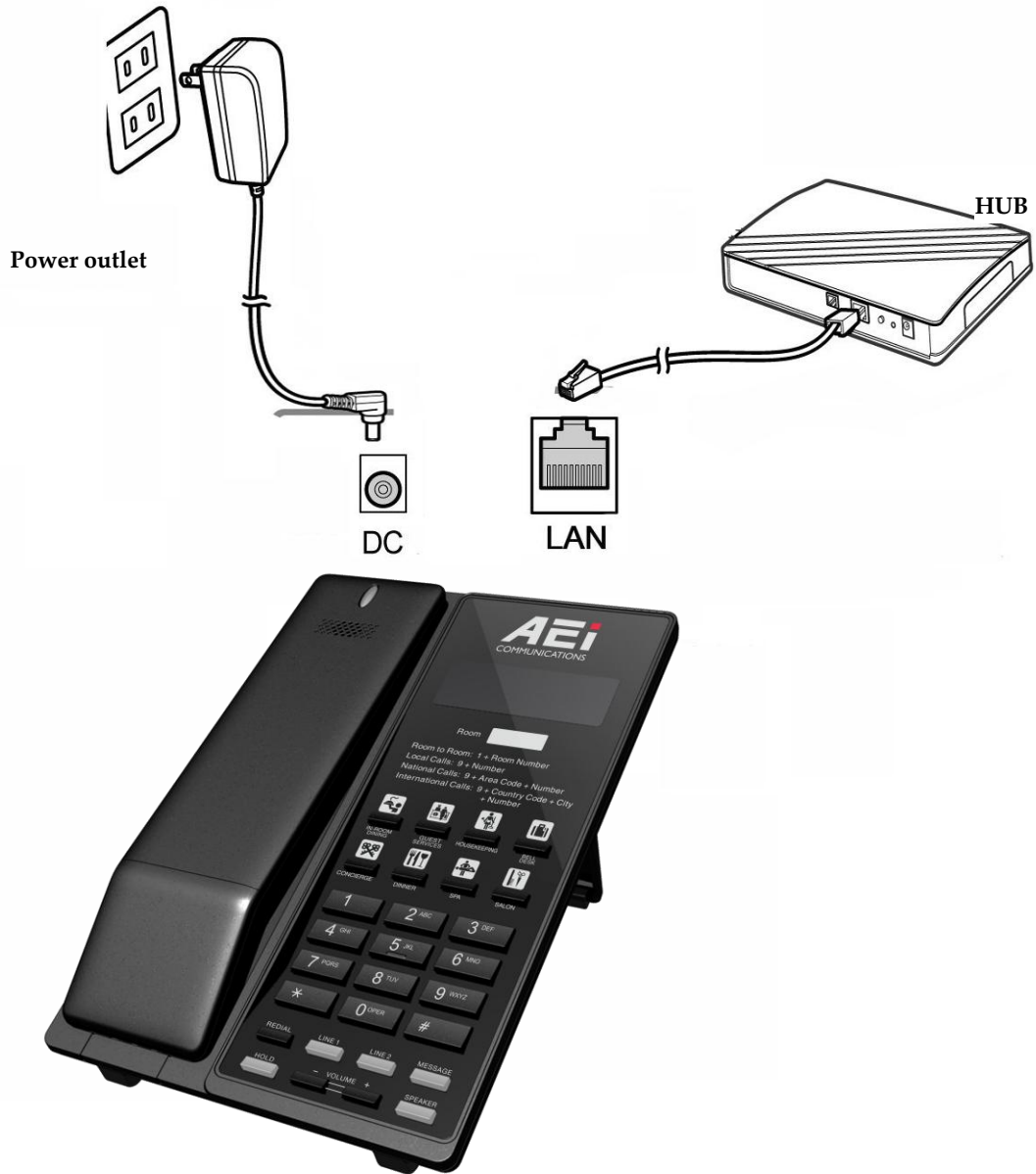

The following illustration shows how to install the phone and stand.

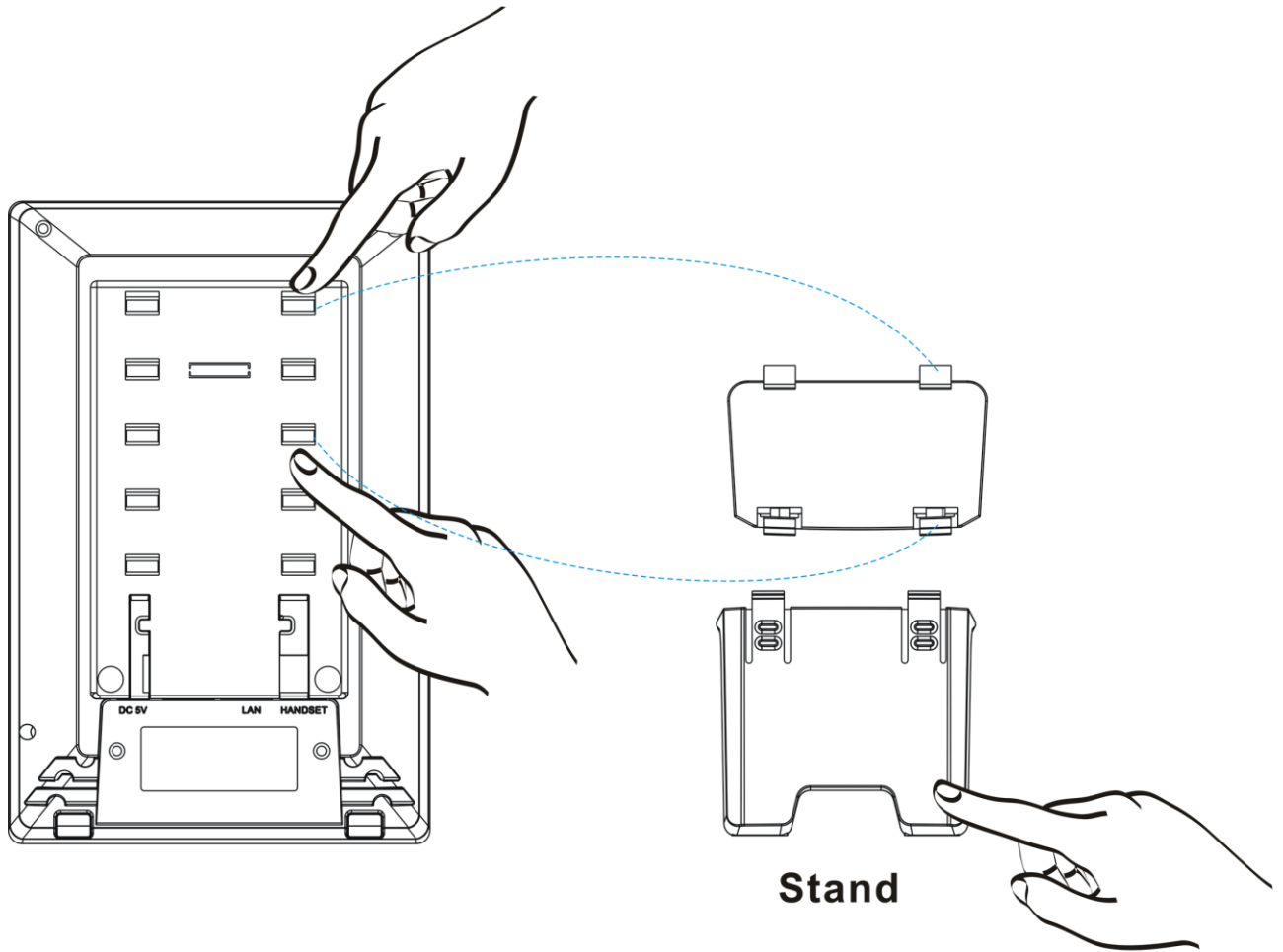

The following illustration shows how to install the handset and battery.

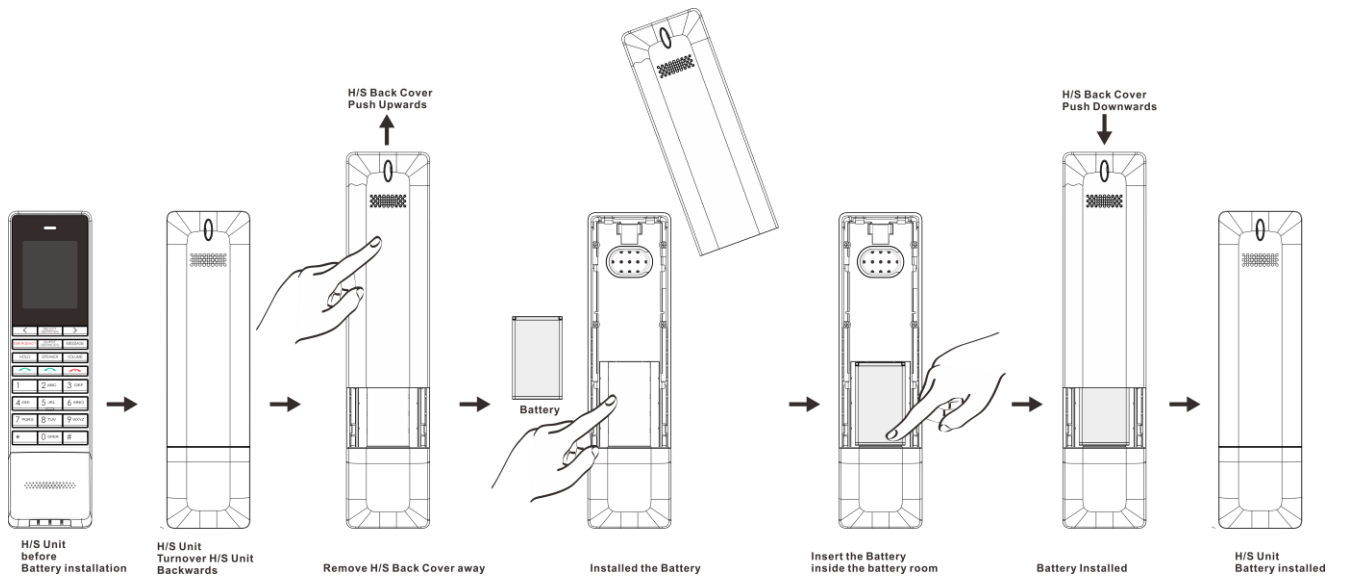

## 3 Operation

### Answering a Call

An incoming call is indicated by a ringing tone and a flashing indicator at the top of both handset and base units. You can answer the call by doing one of the followings:

- Pick up the **handset** to answer the call.
- Press the **Line (Line1/Line2)** key on the base or handset to answer the call.

### Making a Call

#### Dialing with the Keypad

- Enter the telephone number with the alphanumerical keypad.
- After entering the number you want to call, press the # key to force dialing or wait for 4 seconds before the number is dialed automatically.

### Using the pre-assigned speed dial hotkeys on base and handset

You can use the pre-assigned speed dial hotkeys, to configure the most commonly dialed numbers. Use the function to dial a number quickly, instead of keying in a complete number.

To call a number using speed dialing, follow the steps below:

- Press the speed dial hotkey that has been pre-assigned to the phone number and the call will start automatically.

### Using the service function keys on handset

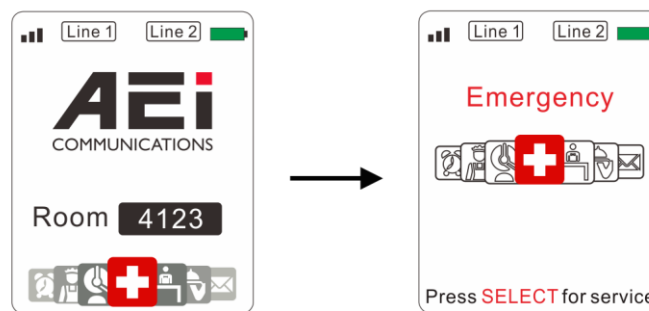

You can use the pre-assigned service function, to configure the most commonly dialed numbers. Use the function to dial a number quickly, instead of keying in a complete number.

To call a number using speed service dialing, follow the steps below:

- Press **SELECT SERVICES** key and use right/left key to select service.
- Press **SELECT SERVICES** key again to precede service dial.

### Call Options

While a call is in progress, following additional options are available.

### Using the Speaker Phone

For hands free operation, you can use the built-in speaker to talk on the phone. To use the speakerphone, follow the steps below:

- While talking on the phone, press the **SPEAKER** key on the phone to enable the Speakerphone function.
  - Press **SPEAKER** key again to terminate the call.
-

## Putting a Call on Hold

You may want to put a call on hold temporarily while doing some work or attending to a second incoming or outgoing call. To put a call on hold, do one of the following:

- Press the **HOLD** key on the phone to put the call on hold.
- When you receive a second call, press the next available **LINE** key to attend to the new call, and the first call will be put on hold automatically.

## Charging the Handset Battery

You would need to charge the handset battery before using the handset.

- Install the battery into the handset.
- Place the handset onto the base unit and base unit will start to charge the handset automatically.
- The charging indicator lights up in red during charging progress. The LED goes off after the handset battery is fully charged.

## Checking Voice Messages

If the **message waiting indicator** at top of handset lights up in red, it indicates that there are one or more new messages in voicemail box.

- Press the **MESSAGE** key on the phone to retrieve voice messages.

(An external ITSP or PBX must support voice message feature. And you need to set a voice message code before using the voice mail feature.)

## Pairing handset and base unit

To pairing handset and base:

- Put handset on the base, the base will start pairing automatically.
- After finished pairing, the base will play the beep tones.

## Charging the Handset Battery

You would need to charge the handset battery before using the handset.

- Install the battery into the handset.
- Place the handset onto the base unit and base unit will start to charge the handset automatically.
- The **message waiting indicator** at top of handset lights up in red.

# 4 Support

To configure through the web browser, do the following:

- Ensure the phone is powered up and connected to a DCHP network.
- Press **HOLD/MUTE \*112\*113#** (**HOLD** for 2-Line / **MUTE** for 1-Line), the IP address is displayed on the LCD screen.
- Open your browser (such as Internet Explorer, Firefox, etc.) and type in the web address of the phone. For example, if the IP address you obtain in step 4 above is 192.168.1.2, enter the web address: [http:// 192.168.1.2:8000](http://192.168.1.2:8000).
- When the Web login front page is displayed. Enter the user name and the password and click **Login**. The administrator's user name and password are "**admin**" and "**1234**" respectively.

For technological support, please email to [support@aeicommunication.com](mailto:support@aeicommunication.com).

---